

NOZZLE CHART	
NOZZLE ID	NPT SIZE
N1	1/4
N2	1
N3	1 1/4
N4	3
N5	6
N6	MANWAY

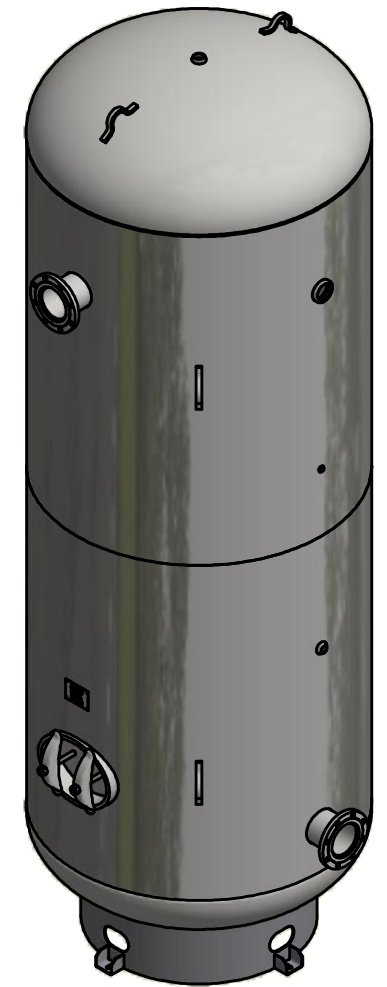
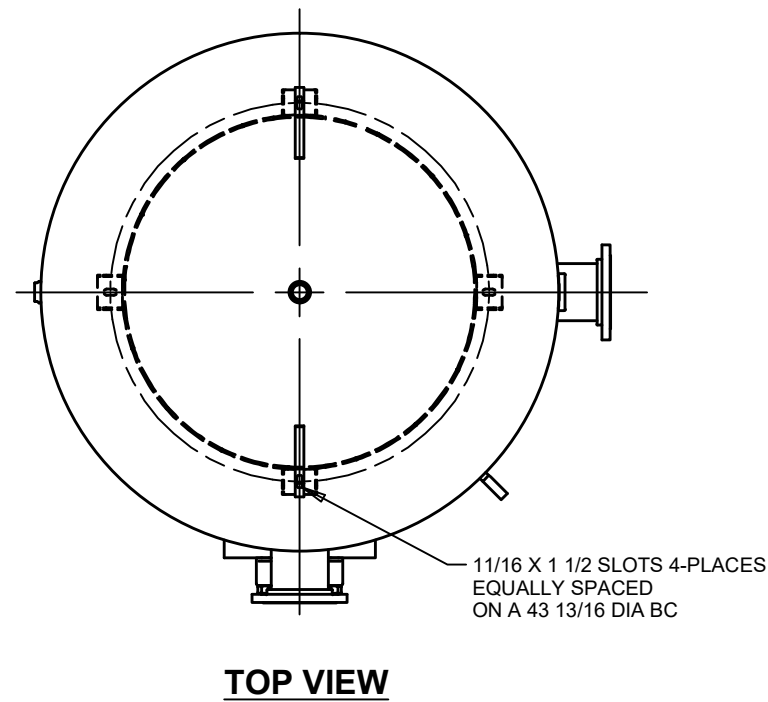
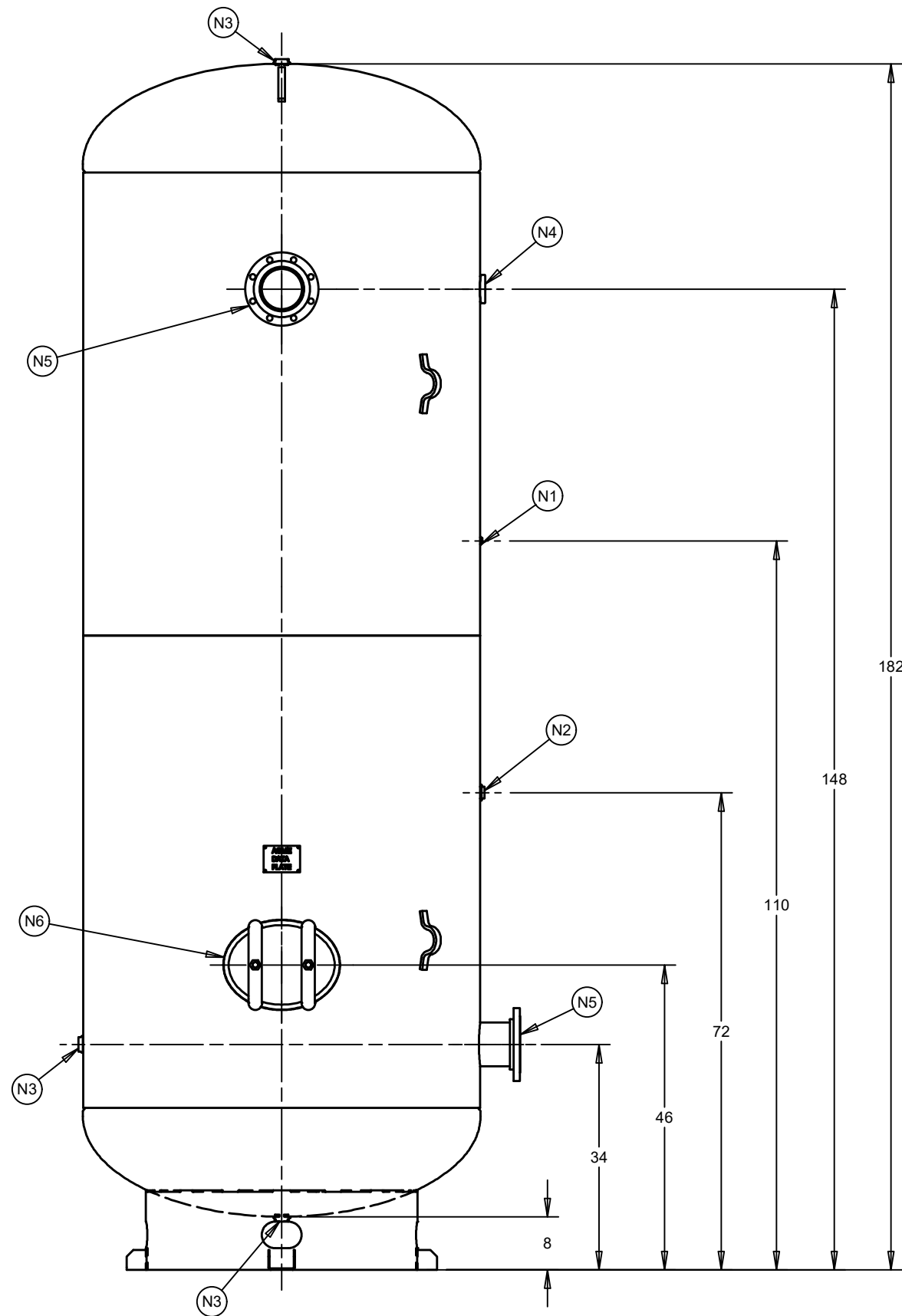

DESIGN INFORMATION	
SPECIFICATION	VALUE
DIAMETER O.D./I.D.	60 O.D.
MAWP	150 PSI AT 400°F
MDMT	-20°F AT 150 PSI
CAPACITY	APPROX 2000 GALLONS
SHIPPING WEIGHT	3503 LBS
CRN	L6794.56801234T9YN

TITLE VERTICAL AIR RECEIVER					
CUSTOMER STOCK		DRAWN KAT	CHECKED DMM	DRAWING NO A10333	REV E22
TYPE ASME		DATE 9/14/2016	DATE 10/10/2016	SIZE: B SHEET 1 OF 1	

REV	DESCRIPTION	BY	DATE
E22	ISSUED		

(BUILT IN ACCORDANCE WITH LATEST EDITION OF SECTION VIII DIV 1 ASME CODE)

THIS DRAWING & SPECIFICATIONS ARE PROPERTY OF SPVG AND MAY NOT BE COPIED, REPRODUCED, OR USED IN WHOLE OR PART, AS A BASIS FOR DESIGN MANUFACTURE OR SALE WITHOUT PRIOR PERMISSION FROM SPVG.